

Codice Dianflex: 109-E57005



SCHEDA TECNICA - TECHNICAL SHEET

29/09/2020

Rev: 0

Codice - Code:

E57005

Shut-off handspray set with stop valve

Descrizione - Description:

Rubinetto d'arresto da 1/2" M con vitone a dischi di ceramica, supporto doccia girevole con doccetta a pulsante in ottone e flessibile cm 125

Stop valve with 1/2" M ceramic discs headwork, swivelling shower bracket with brass shut-off handspray and hose 125 cm

Keramikscheiben-Stoppventil 1/2" M a.G. mit schwenkbarem Brausehalter, Brause aus Messing mit Abschaltssystem und Schlauch cm 125

Robinet d'arrêt à disques ceramiques 1/2" M avec support de douche orientable, douchette d'arrêt en laiton et flexible cm 125

Llave de paso de 1/2" M con discos de cerámica soporte de ducha orientable, mango en latón con pulsante de cierre y flexible cm 125

Комплект запорный вентиль 1/2" M на керамических дисках и поворотный держатель, лейка с клапаном подачи из латуни и шланг 125 см

Tecnologia - Technology:



Immagine Prodotto - Product Image



Disegni - Drawings



Grafico di portata - Flow rate diagram

	free outlet
0	0,0
0,5	5,6
1	8,2
1,5	9,9
2	11,4
2,5	12,9
3	14,3
3,5	15,4
4	16,5
4,5	17,7
5	18,6
pressione bar	portata L/min

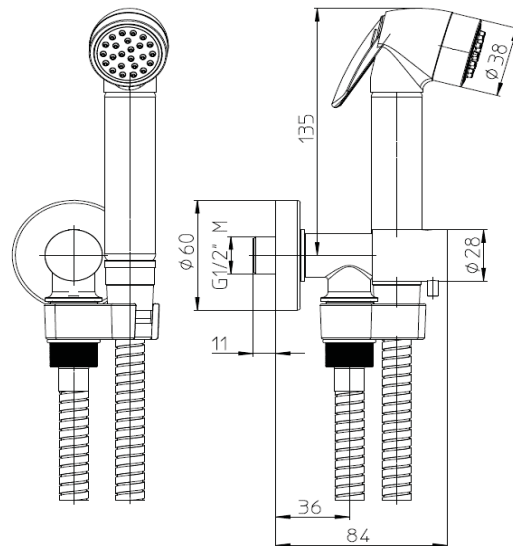
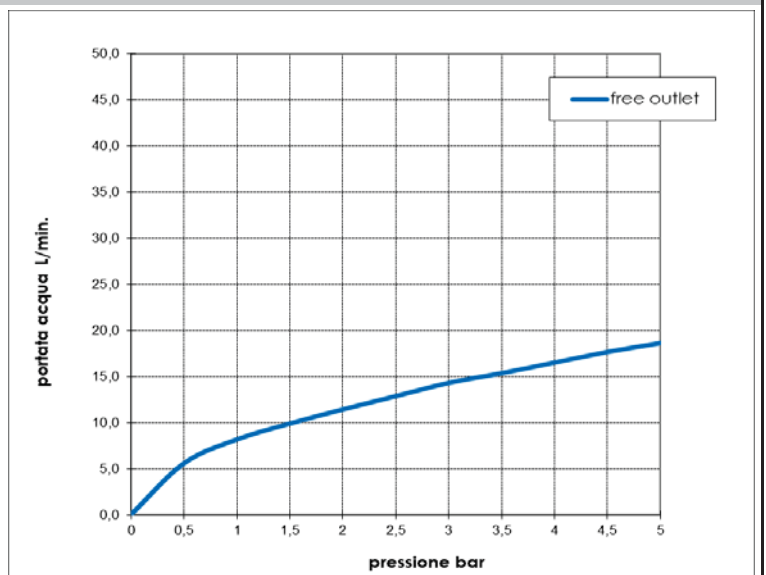

Caratteristiche idrauliche - Hydraulic features

		Pressione Pressure	Portata Flow rate	Solo per miscelatori termostatici Only for thermostatic mixers	
min		1 bar	8 L/min	Blocco di sicurezza Safety lock	--
max		5 bar	18,5 L/min	Temperatura acqua fredda Cold water temperature	--
Portata minima consigliata per buon funzionamento <i>Recommended minimum flow-rate for optimal performace</i>			5L/min	Temperatura acqua calda Hot water temperature	--

Materiali - Materials

Doccia B00653: Ottone con ugelli in silicone
Rubinetto di arresto E57000: Ottone cromato
Flessibile A03045: Ottone doppia agraffatura, cromato

*Shut-off shower B00653 : Brass with silicone nozzles
 Water inlet with stop valve E57000 : Brass, chrome plated
 Hose A03045 : Double interlock brass, chrome plated*

Certificazioni - Certifications

Hose A03045:



Conformità' - Conformity

Water inlet with stop valve E57000 - EN 200; EN 817; **Chrome plating** - EN 248