

REMER

SCHEDA TECNICA

TECHNICAL FEATURES

RUBINETTERIE

ART. COD.

N64W

MANOPOLA FLUSSO
FLOW KNOB
APERTURA PROGRESSIVA
PROGRESSIVE OPENING

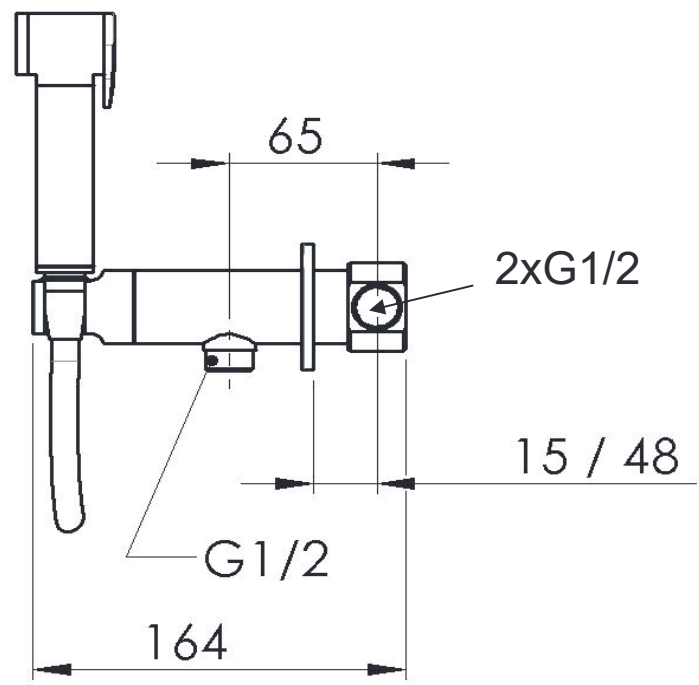
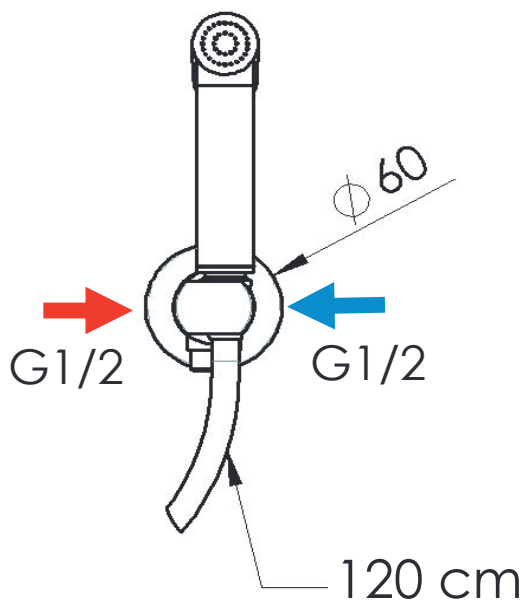

MATERIALI / MATERIALS

OTTONE CROMATO / CHROME PLATED BRASS

ACCIAIO INOX / STAINLESS STEEL

CROMATURA / CHROME PLATING

UNI EN 248