

Codice Dianflex: 110-166

REMER

SCHEDA TECNICA

TECHNICAL FEATURES

RUBINETTERIE

ART. COD.

3320Z

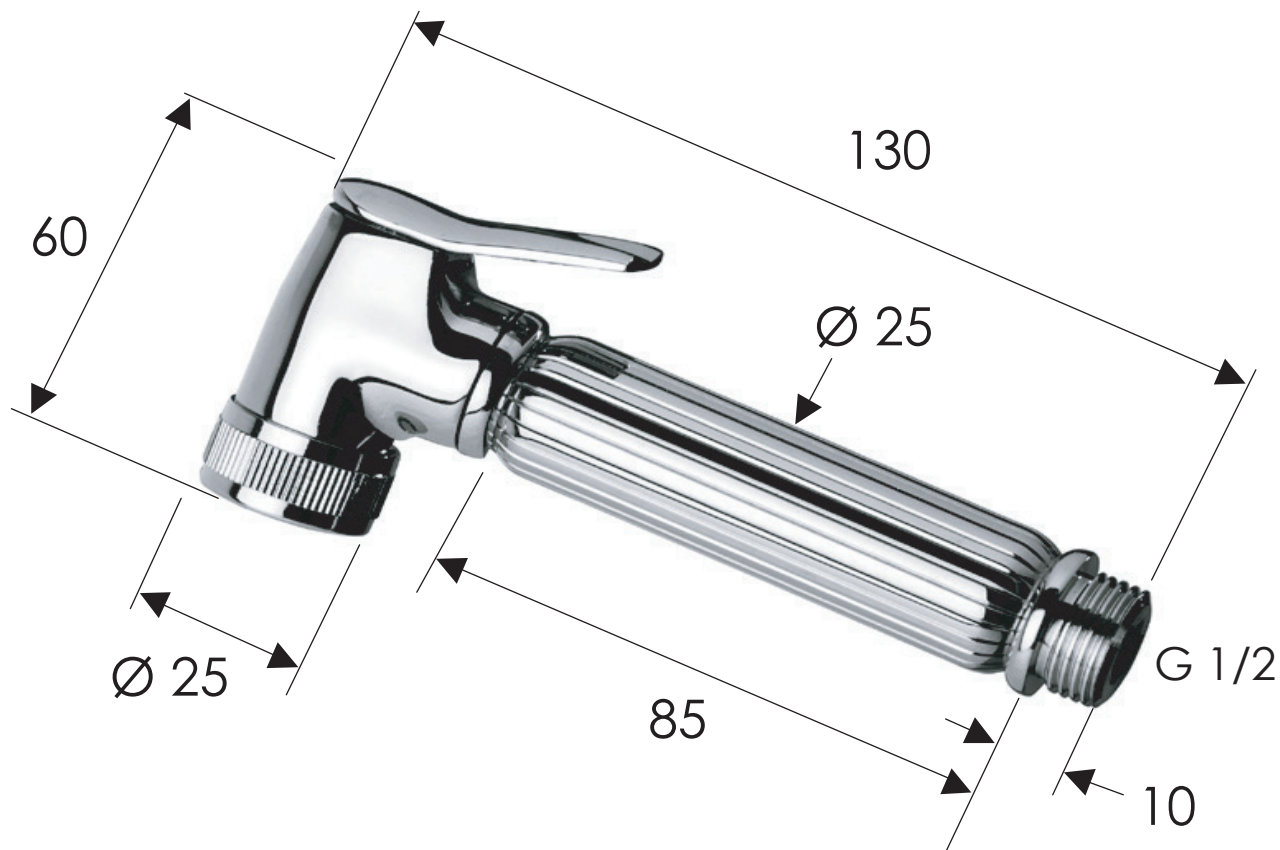

PRESSIONE / PRESSURE
PORTATA / FLOW RATE

0,5 bar	1 bar	2 bar	3 bar	4 bar	5 bar
7 l/min	10,5 l/min	13 l/min	15 l/min	16,5 l/min	18,5 l/min

MATERIALI / MATERIALS

OTTONE CROMATO / CHROME PLATED BRASS
CW614N - CW617N

CROMATURA / CHROME PLATING

UNI EN 248