



Codice

145-L203

Categoria

145

Prodotto

**Specchio led rettangolare mod. Valerio  
Linea Vanitas**

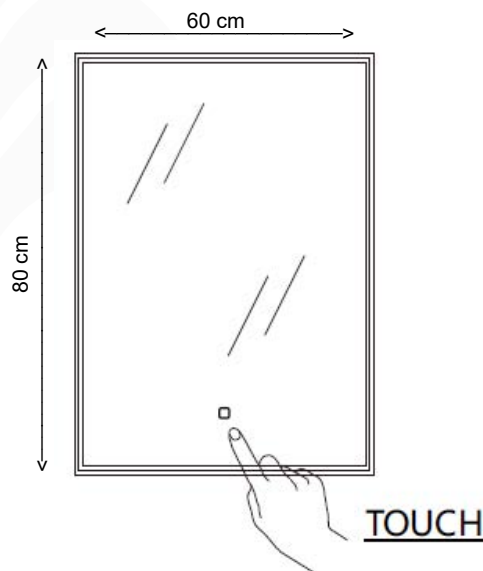
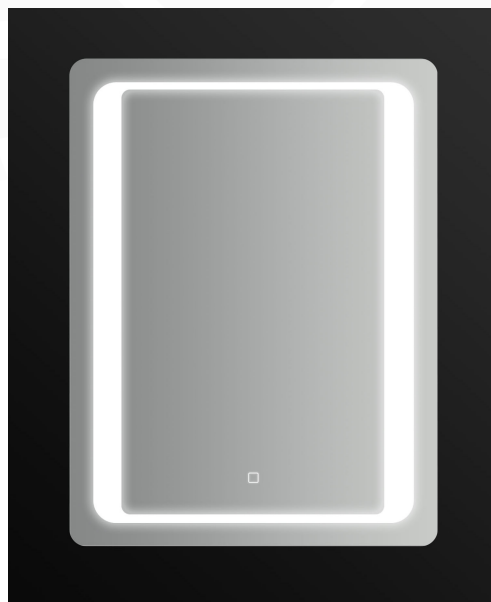

**DESCRIZIONE DEL PRODOTTO**

Specchio rettangolare con illuminazione LED

<b>Dimensioni</b>	60x80 cm, spessore 5mm
<b>Illuminazione</b>	Strip LED 6500K con accensione touch screen
<b>Alimentazione</b>	220-240V, 50/60 Hz Protezione IP44

