



NOVELLINI



iris

DATA SHEET

- IT Caratteristiche tecniche
 FR Caracteristiques techniques
 EN Technical specifications
 DE Technische eigenschaften
 NL Technische kenmerken
 ES Características técnicas
 PT Características técnicas
 AR المواصفات الفنية

Mod.	Capienza Capacité Capacity Kapazität Capaciteit Capacidad Capacidade السعة	Carico Max per m ² Charge Max par m ² Max load per sq.m Max Belastung pro mq. Max. belasting per m ² Carga Max por m ² Carga máx. por m ² الحد الأقصى للحمل في المتر المربع	Capacità litri Capacité en litres Capacity in litres Fassungsvermögen in Liter Inhoud in liters Capacidad litros Capacidade em litros السعة باللترات	Tensione Tension Voltage Spannung Spanning Tensión Tensão الفولت	Frequenza Fréquence Frequency Frequenz Frequentie Frecuencia Frequência التردد	Potenza max assorbita Puissance absorbée Absorbed power Aufgenommene Leistung Geabsorbeerd vermogen Potencia absorbida Potência máx. absorvida الطاقة الممتصة	
						Whirlpool 500/20	Whirlpool + Airpool 500/30
IRIS sx	1	390 kg/m ²	265	230 V	50 Hz	550 W	950 W
IRIS dx	1	390 kg/m ²	265	230 V	50 Hz	550 W	950 W

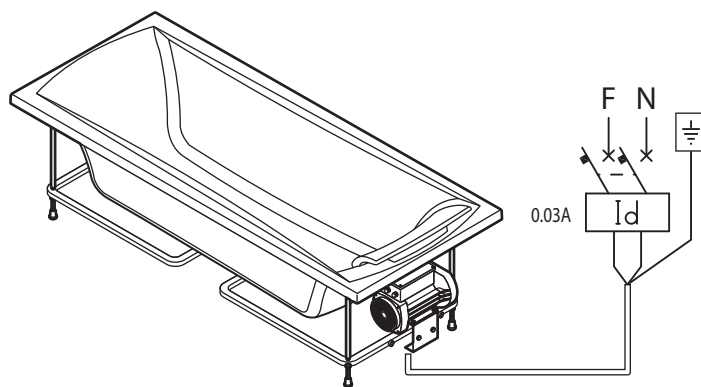
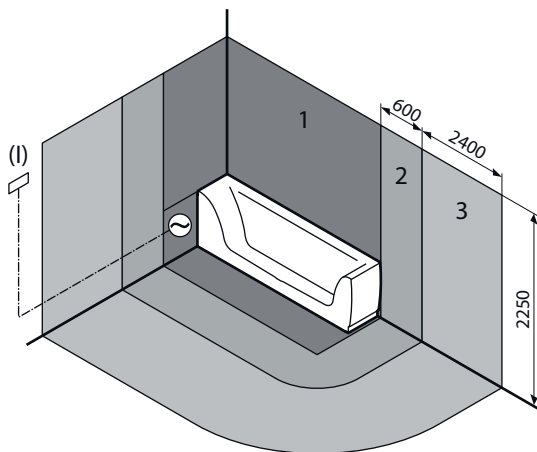

- IT Verificare dati di targa
 FR Voir plaque signalétique
 EN See data plate
 DE Siehe Typenschild
 NL Zie label
 ES Vea la placa de datos
 PT Consulte a placa de dados
 AR رؤية لوحة البيانات



	1 5 1/2"	2 6 1/2"	3 ≥ IP55	4	4
IT	Acqua calda	Acqua fredda	Allacciamento elettrico	Area disponibile per lo scarico	Area consigliata
FR	Eau chaude	Eau froide	Raccordement électrique	Espace prévu pour l'évacuation	Espace recommandé
EN	Hot water	Cold water	Electrical connection	Area provided for drain pipe	Recommended area
DE	Warmwasser	Kaltwasser	Stromanschluss	Verfügbarer Bereich für den Abfluss	Empfohlener Bereich
NL	Warm water	Koud water	Electrische aansluiting	Beschikbaar gebied voor de afvoer	Aanbevolen gebied
ES	Agua caliente	Agua fría	Conexión eléctrica	Área disponible para la descarga	Área recomendada
PT	Água quente	Água fria	Ligação eléctrica	Área disponível para o tubo de esgoto	Área recomendada
AR	الماء الساخن	الماء البارد	التوصيلات الكهربائية	منطقة مخصصة لأنبوب التصريف	المنطقة الموصى بها

IRIS dx

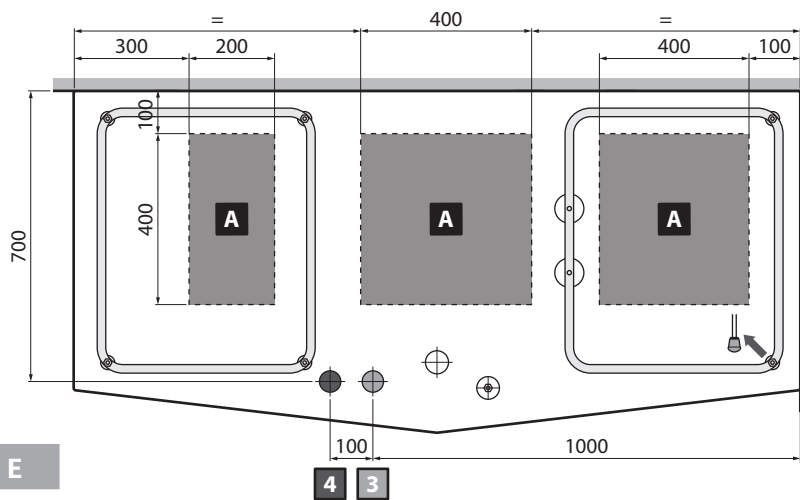
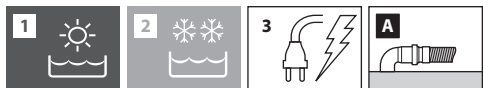
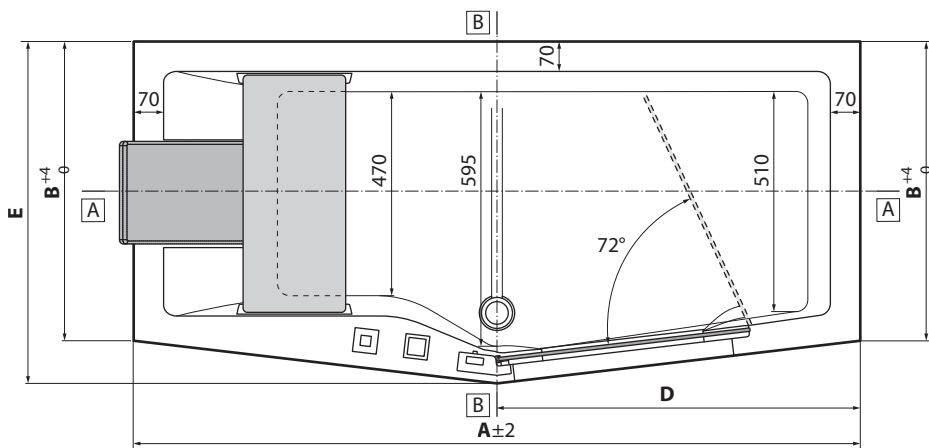
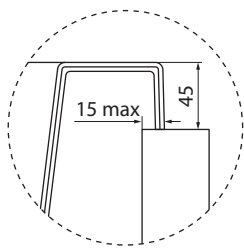
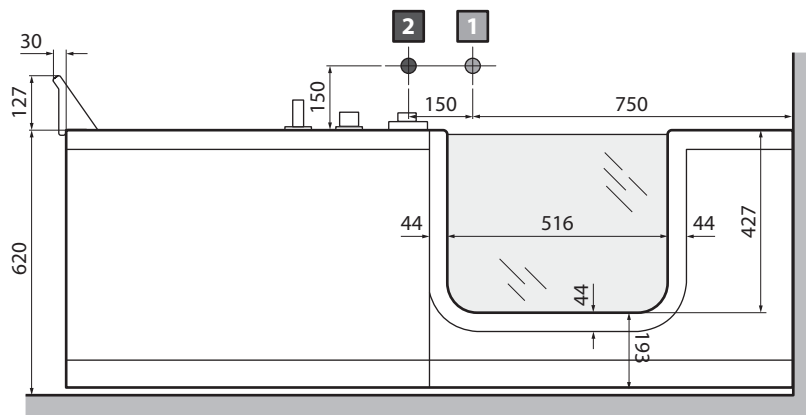
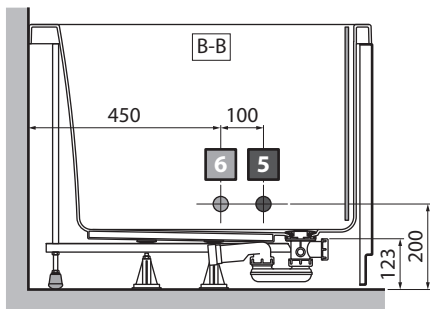
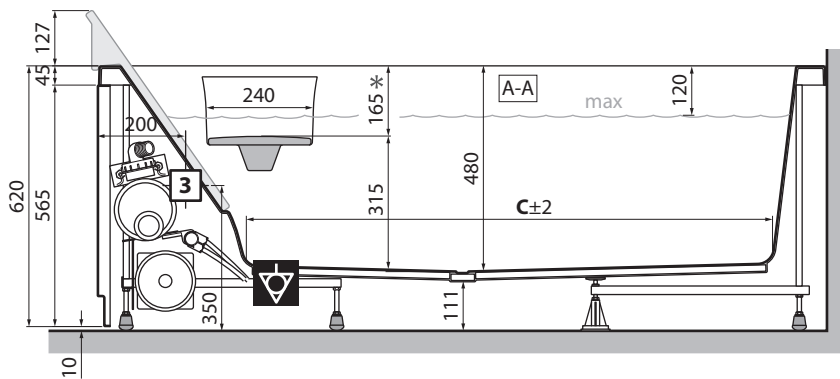

Mod.	A	B	C	D	E
160x70/80	1600	700	1130	850	800
170x70/80	1700	700	1235	850	800

- IT Allacciamento idraulico
- FR Raccordement hydraulique
- EN Water connection
- DE Wasseranschluss
- NL Hydraulische aansluiting
- ES Conexión hidráulica
- PT Ligaçao hidráulica
- AR توصيلات المياه

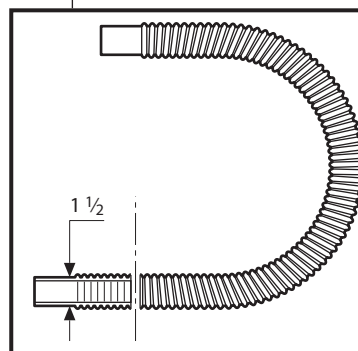
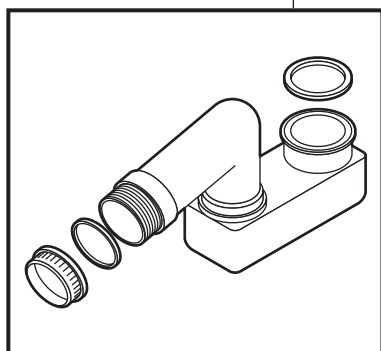
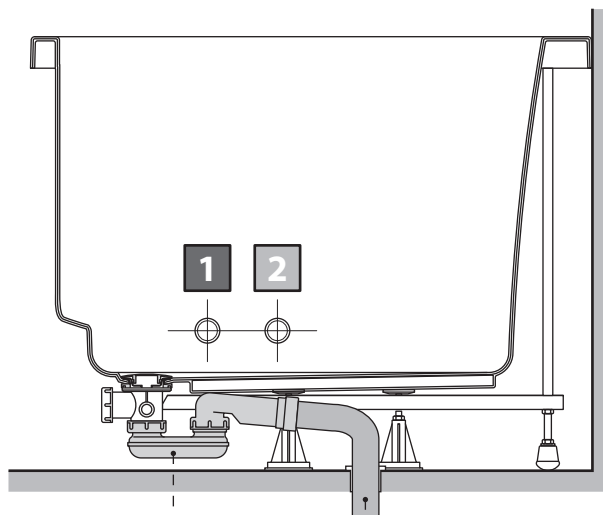

- IT non fornito
- FR non fourni
- EN masonry bit (not supplied)
- DE nicht im Lieferumfang
- NL niet bijgeleverd
- ES no incluida
- PT não incluída
- AR غير مرفقة

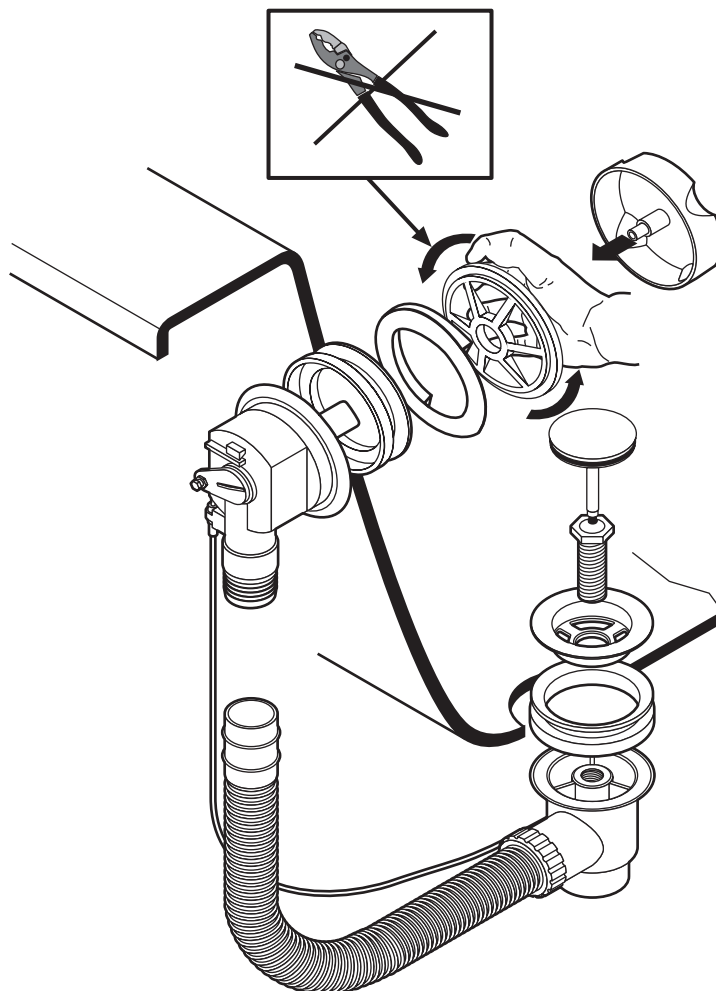

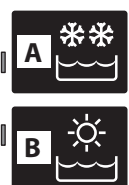
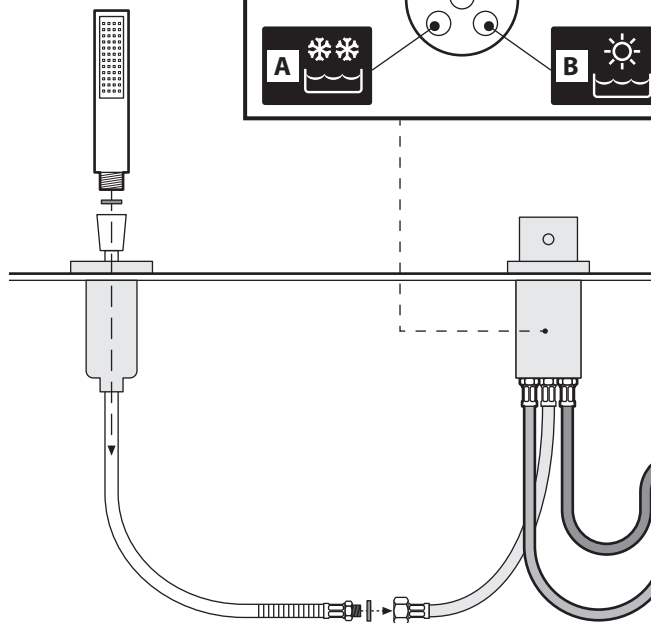
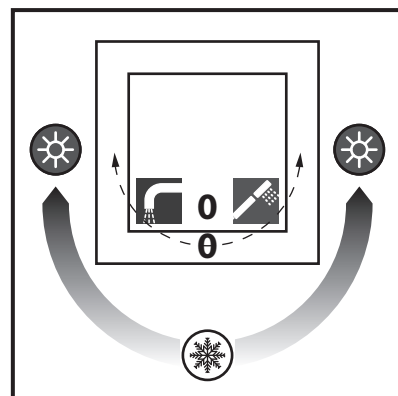
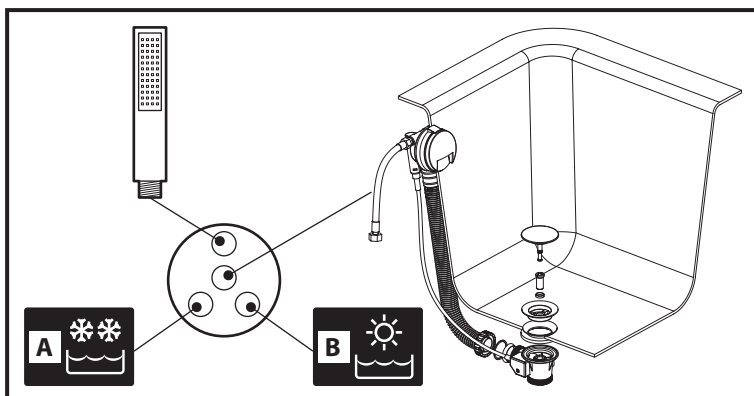
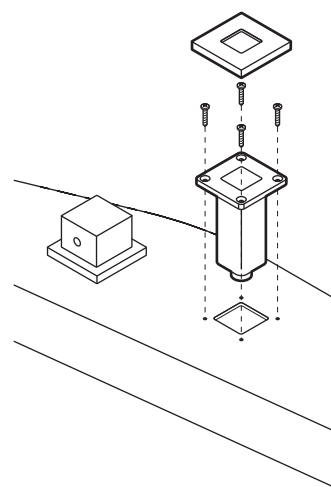
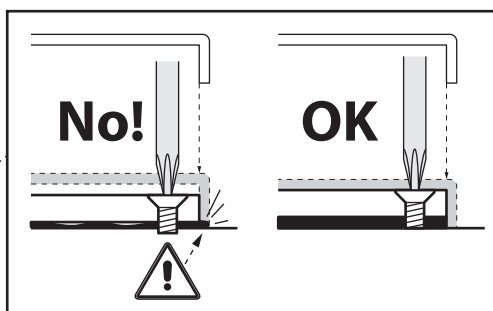
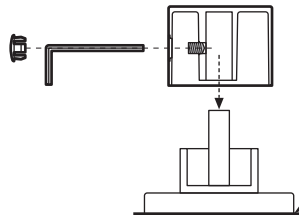
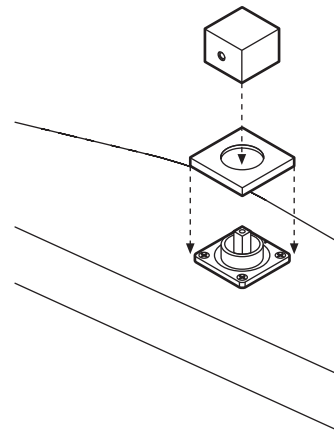
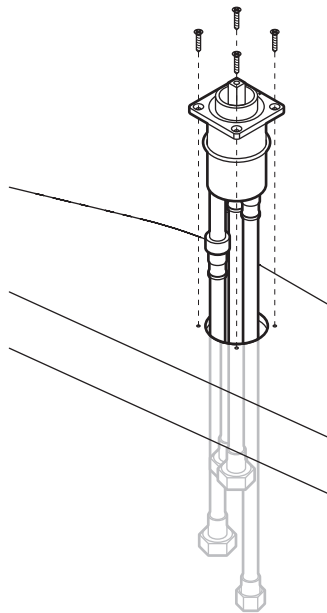
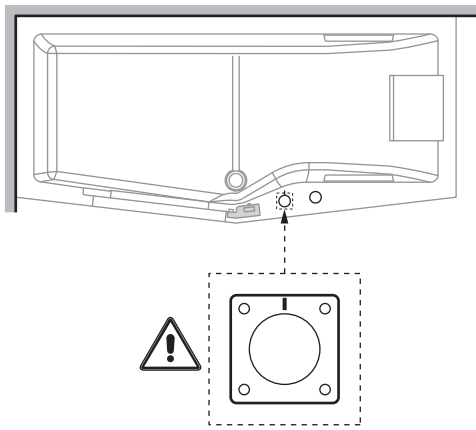

- IT non forniti
- FR non fourni
- EN masonry bit (not supplied)
- DE nicht im Lieferumfang
- NL niet bijgeleverd
- ES no incluida
- PT não incluída
- AR غير مرفقة

1/2'