

ARTICOLO / Item
Artículo / Article

02061

R1

Rubinetto a pedale per montaggio a pavimento.

Foot operated tap, floor mounted type.

Grifo a pedal fijación al suelo.

Robinet simple à pédale fixation au sol.

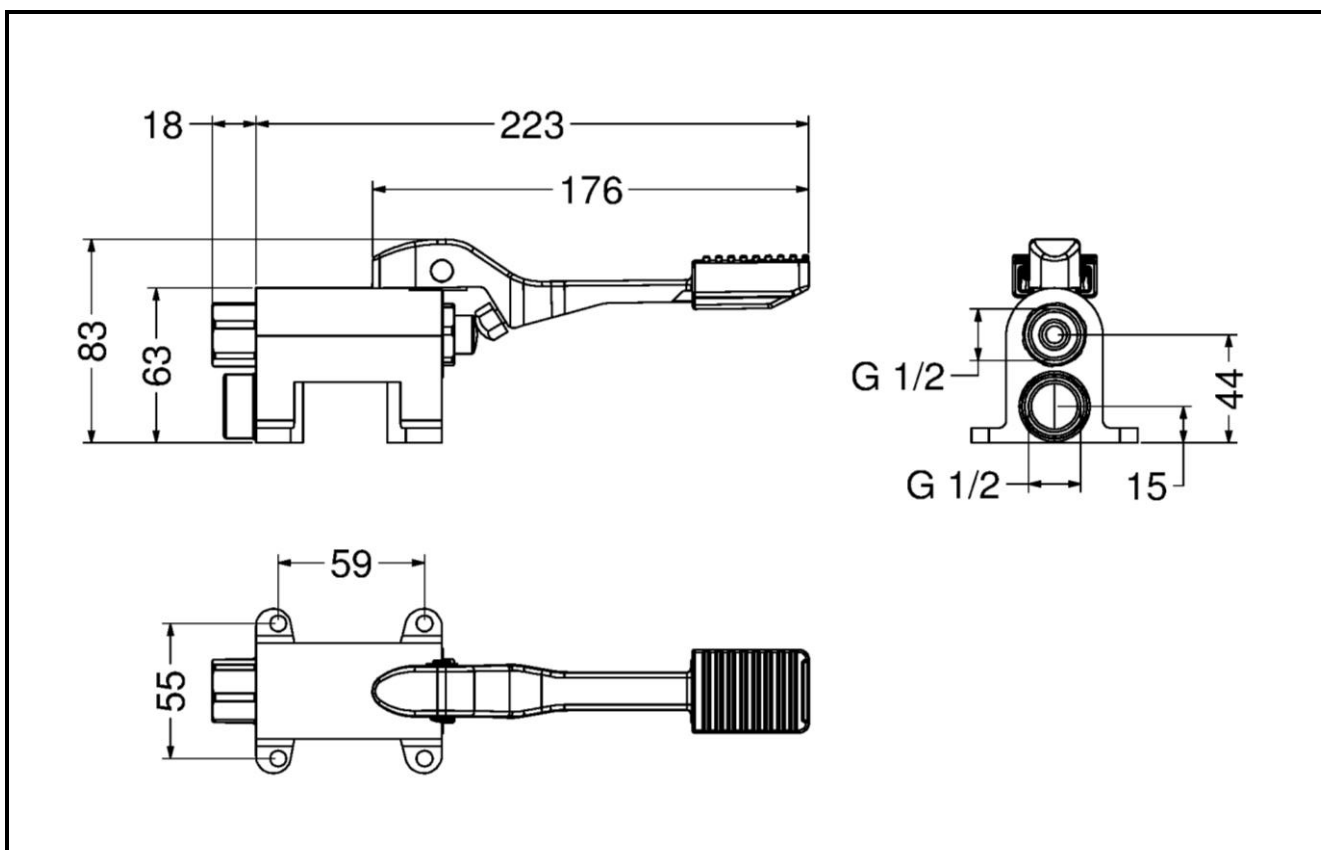

IT



COMPOSIZIONE

- Corpo pedale in ottone cromato
- Leva in Zamak con copripedale in gomma
- Kit di fissaggio
- Guarnizione con filtro 1/2"

CARATTERISTICHE FUNZIONALI

Pressione di alimentazione: Min 0.5 – max 8 bar

Temperatura di alimentazione: 5 – 65 °C

EN



COMPOSITION

- Chromed brass tap's body
- Zamak lever with rubber cover
- Fixing kit
- 1/2" joint with filter

OPERATING CHARACTERISTICS

Operating pressure: Min 0.5 – max 8 bar

Water inlet temperature: 5 – 65 °C

ES



CARACTERÍSTICAS

- Cuerpo pedal en latón cromado
- Palanca en Zamak y cobertura en goma
- Kit de fijación
- Junta con filtro 1/2"

CARACTERÍSTICAS FUNCIONALES

Presión de alimentación: Min 0.5 – max 8 bar

Temperatura de alimentación: 5 – 65 °C

FR



CARACTÉRISTIQUES

- Corps pédale en laiton chrome
- Levier en Zamak avec couverture en caoutchouc
- Kit de fixation
- Joint avec filtre 1/2"

CARACTÉRISTIQUES FONCTIONNELLES

Pression d'alimentation: Min 0.5 – max 8 bar

Température d'alimentation: 5 – 65 °C

