

ARTICOLO / Item
Artículo / Article / Artikel

02064

R2

Rubinetto a pedale per montaggio a parete.
Foot operated tap, wall mounted type.
Grifo a pedal fijación mural.
Robinet simple à pédale fixation murale.
Pedalarmatur mit Fußbedienung, wandmontiert.

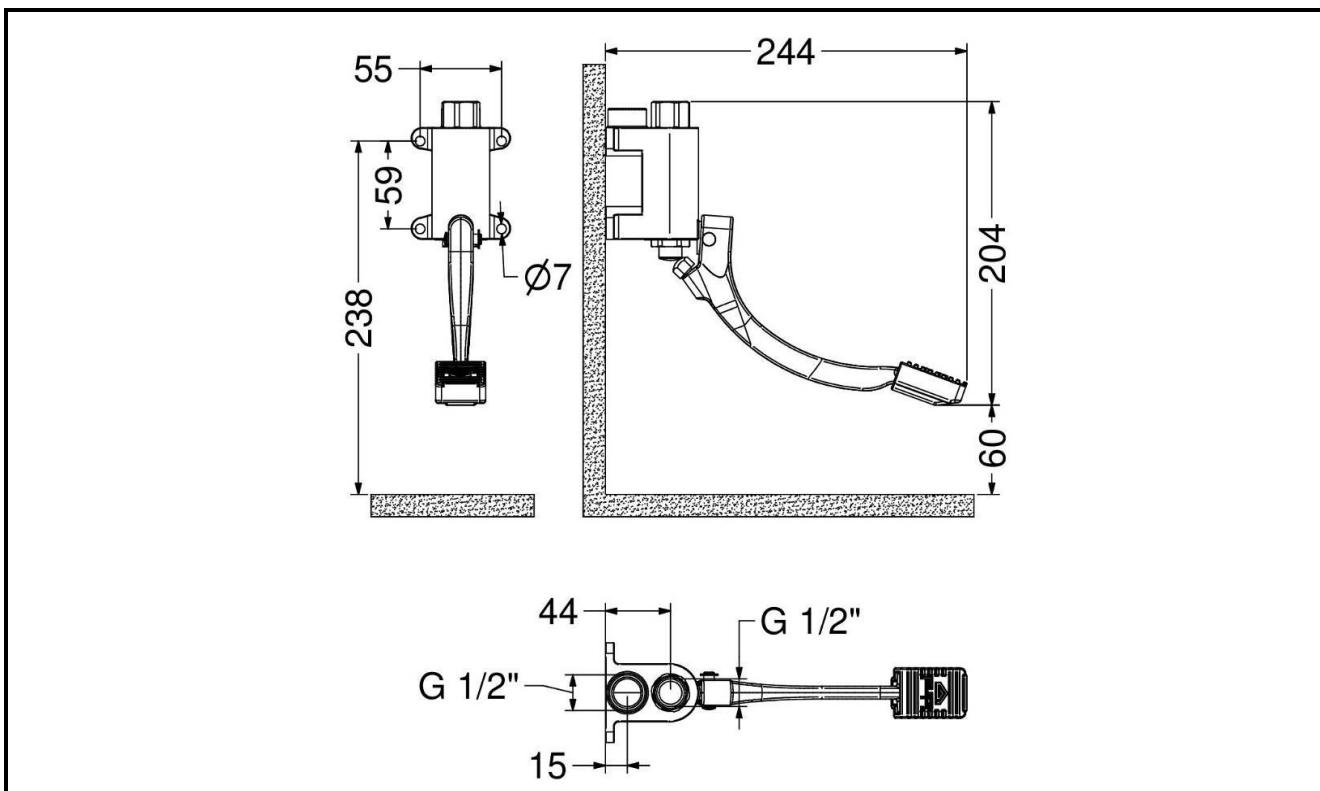

IT



COMPOSIZIONE

- Corpo pedale in ottone cromato
- Leva in ottone con copripedale in gomma
- Kit di fissaggio
- Guarnizione con filtro 1/2"

CARATTERISTICHE FUNZIONALI

Pressione di alimentazione: Min 0.5 – max 8 bar

Temperatura di alimentazione: 5 – 65 °C

EN



COMPOSITION

- Chromed brass tap's body
- Brass lever with rubber cover
- Fixing kit
- 1/2" joint with filter

OPERATING CHARACTERISTICS

Operating pressure: Min 0.5 – max 8 bar

Water inlet temperature: 5 – 65 °C

ES



CARACTERÍSTICAS

- Cuerpo pedal en latón cromado
- Palanca en latón y cobertura en goma
- Kit de fijación
- Junta con filtro 1/2"

CARACTERÍSTICAS FUNCIONALES

Presión de alimentación: Min 0.5 – max 8 bar

Temperatura de alimentación: 5 – 65 °C

FR



CARACTÉRISTIQUES

- Corps pédale en laiton chrome
- Levier en laiton avec couverture en caoutchouc
- Kit de fixation
- Joint avec filtre 1/2"

CARACTÉRISTIQUES FONCTIONNELLES

Pression d'alimentation: Min 0.5 – max 8 bar

Température d'alimentation: 5 – 65 °C

DE



LIEFERUMFANG

- Körper aus verchromten Messing
- Pedal aus Messing mit Gummiüberzug
- Fixierungsset
- Dichtung mit Filter 1/2"

FUNKTIONELLE EIGENSCHAFTEN

Zulaufdruck: min. 0.5 – max. 8 bar

Zulauftemperatur: 5 – 65 °C

