

Codice Dianflex: 242-135

CARATTERISTICHE TECNICHE - TECHNICAL CHARACTERISTICS
 CARACTERÍSTICAS TÉCNICAS - CARACTÉRISTIQUES TECHNIQUES –
 TECHNISCHE EIGENSCHAFTEN

idral
 ITALIAN PARTNER FOR WATER SOLUTIONS

ARTICOLO / Item
Artículo / Article / Artikel

02072/90

R1

Miscelatore progressivo monopedale per montaggio parete.
 Foot operated progressive mixer, wall mounted type.
 Grifo mezclador monopedal progresivo mural.
 Mitigeur progressive à une pédale, fixation murale.
 Progressive Pedal-Mischarmatur mit Fußbedienung,
 wandmontiert.

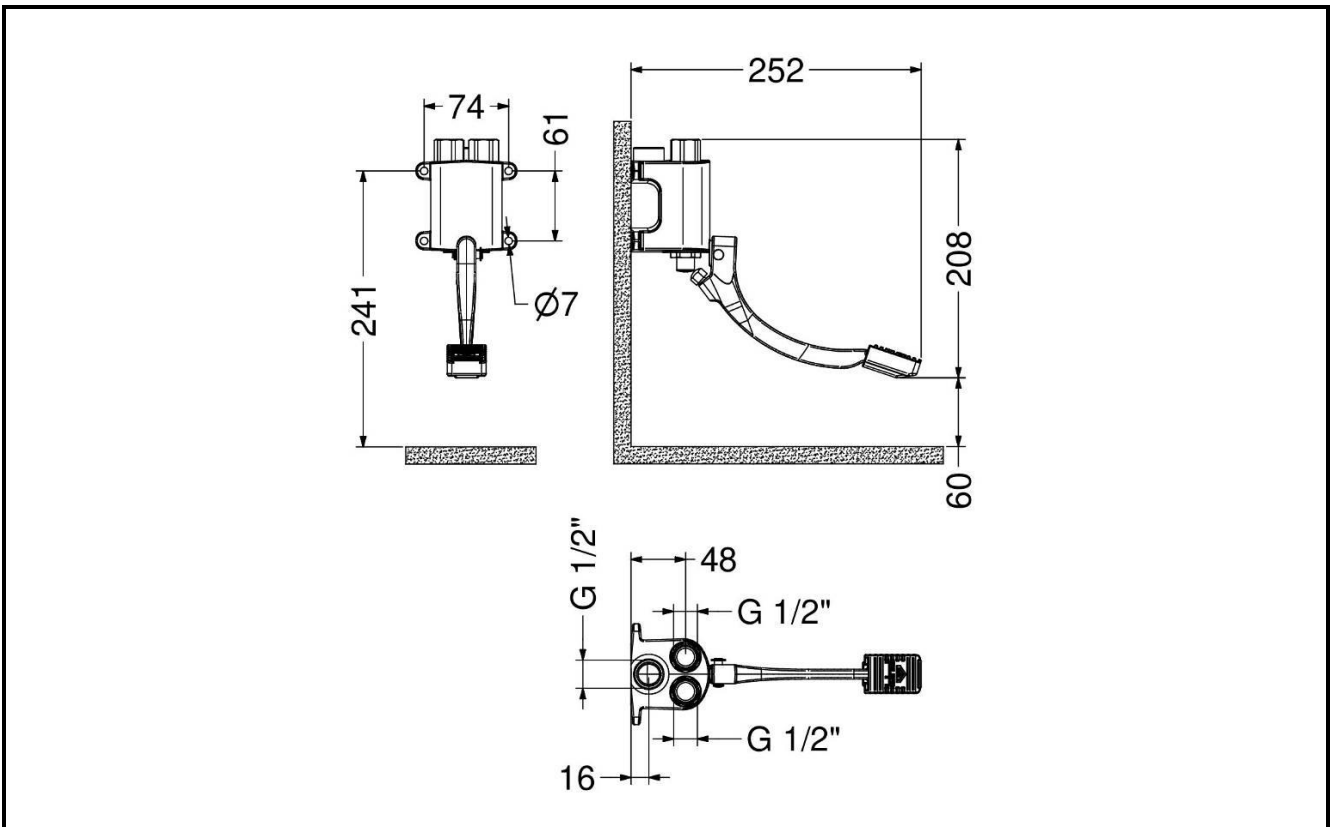

IT



COMPOSIZIONE

- Corpo pedale in ottone cromato
- Leve in ottone con copripedale in gomma
- Kit di fissaggio
- Guarnizioni con filtro 1/2"

CARATTERISTICHE FUNZIONALI

Pressione di alimentazione: Min 0.5 – max 8 bar
Temperatura di alimentazione: 5 – 65 °C

EN



COMPOSITION

- Chromed brass tap's body
- Brass levers with rubber cover
- Fixing kit
- 1/2" joints with filter

OPERATING CHARACTERISTICS

Operating pressure: Min 0.5 – max 8 bar
Water inlet temperature: 5 – 65 °C

ES



CARACTERÍSTICAS

- Cuerpo pedal en latón cromado
- Palancas en latón y cobertura en goma
- Kit de fijación
- Juntas con filtro 1/2"

CARACTERÍSTICAS FUNCIONALES

Presión de alimentación: Min 0.5 – max 8 bar
Temperatura de alimentación: 5 – 65 °C

FR



CARACTÉRISTIQUES

- Corps pédale en laiton chrome
- Leviers en laiton avec couverture en caoutchouc
- Kit de fixation
- Joints avec filtre 1/2"

CARACTÉRISTIQUES FONCTIONNELLES

Pression d'alimentation: Min 0.5 – max 8 bar
Température d'alimentation: 5 – 65 °C

DE



LIEFERUMFANG

- Körper aus verchromten Messing
- Pedal aus Messing mit Gummiüberzug
- Fixierungsset
- Dichtung mit Filter 1/2"

FUNKTIONELLE EIGENSCHAFTEN

Zulaufdruck: min. 0.5 – max. 8 bar
Zulauftemperatur: 5 – 65 °C

