

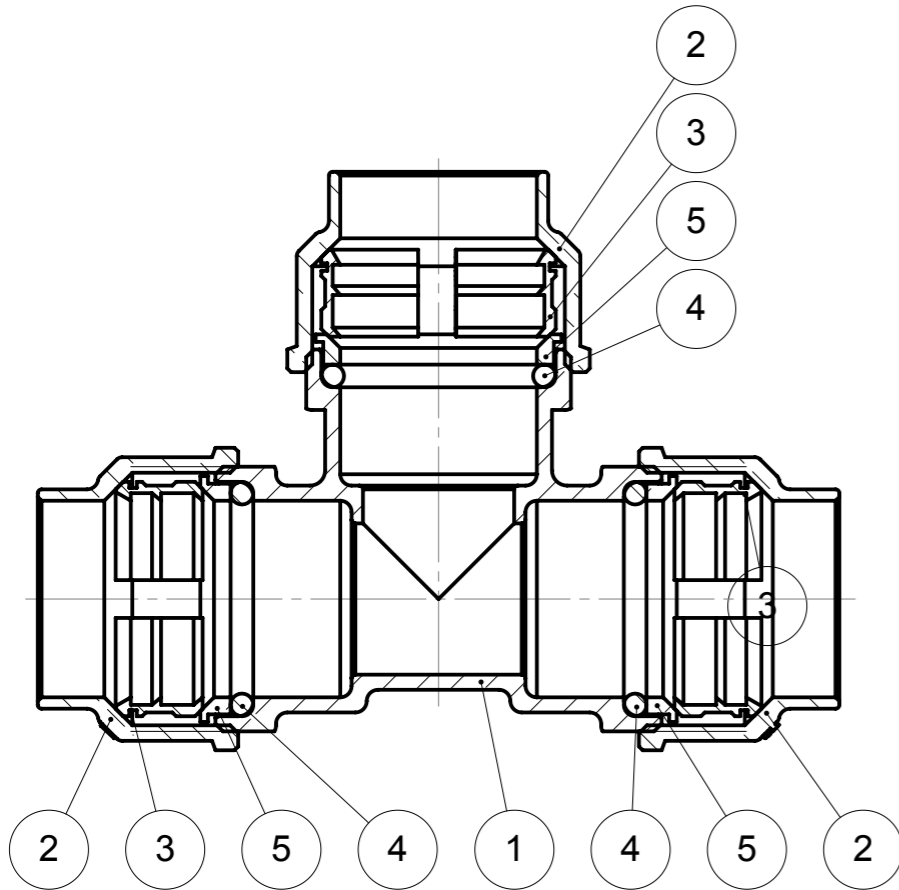

# Codice Dianflex: 332-8030

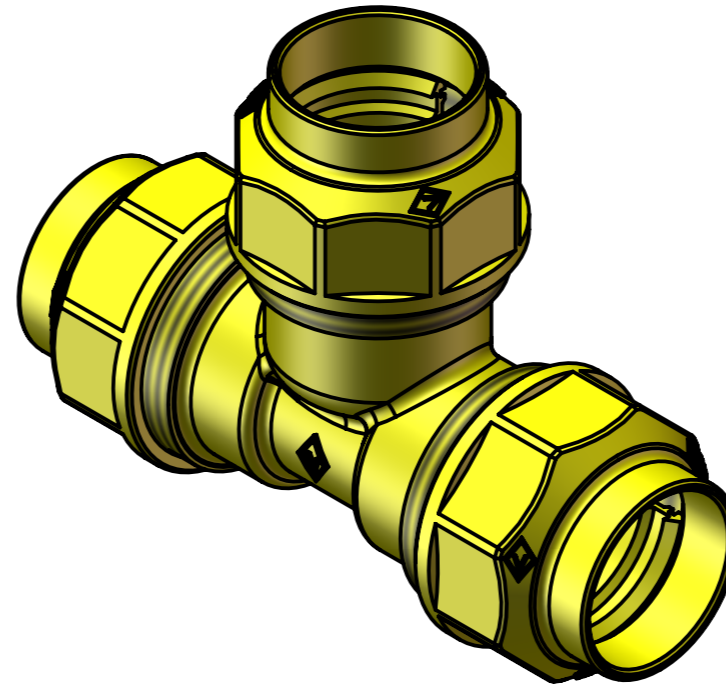
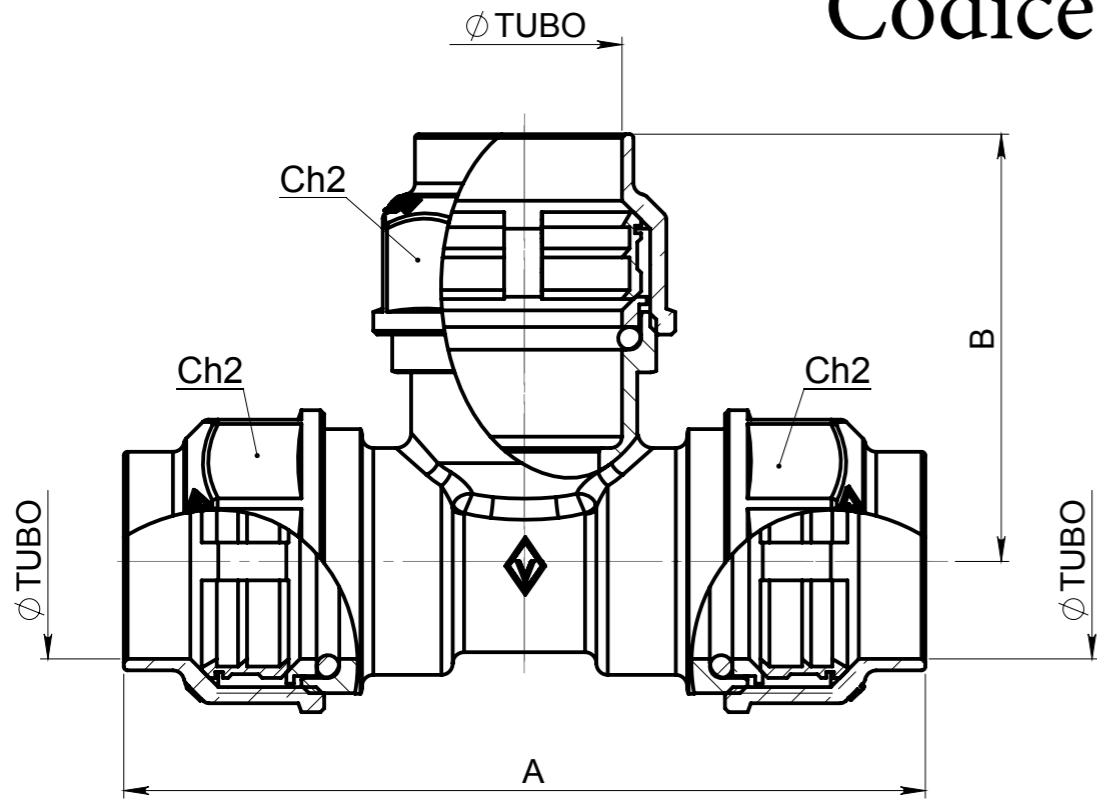

Ø TUBO	A	B	Ch2	PN
20	88	47.5	31	20
32	124	66.5	46	20
40	146	77.5	56	20

ART.8030	
Equal Tee coupler, Mis. from Ø20 to Ø63	
SPECIFICATION	
Series	8030
Thread ends	Pipe-Pipe-Pipe: PE-PE-PE
Pipe Ø	from Ø20 to Ø63 mm
Ø Orifice	-
Operator	-
APPLICATION	
Assembly in rigid pipe system	
Nominal pressure (PN) in bar:20	
KV: flowrate coefficient m <sup>3</sup> /h	
Direction of flow:as desired	
Temperature range: -20 °C / +80°C	
Use:Water	

N°	Descrizione	Description	Materials	Q.ty
1	Corpo raccordo	Body coupler	CW617N	1
2	Dado	Nut	CW617N	3
3	Ghiera	Brass Ring	CW614N	3
4	O-Ring	O-Ring	NBR70sh	3
5	Rondella	Ring	CW614N	3

Denominazione particolare / Name ART.8030 RACC.TU 25		Disegnato / Designed by Pedretti Walter		Formato / Format A3		Grezzo / Forged Code		Quote senza indicazione di tolleranza: MEDIA UNI-ISO 2768/1	
Materiale / Material		Data / Date 08/02/2012		Scala / Scale 1:1		Lavorato / Finished Code		Rugosità Generale <sup>3.2</sup> / ( <sup>0.7</sup> )	
Tratt. Superficiale / Surface Treat.		Tratt. Termico / Thermal Treat.		Serie / Project N° 8030		Foglio / Tab. 1/1		Valido per / Available for Consultazione	
N° Disegno / Drawing Nr. 8030		Revisione / Revision -		Peso / Weight -		Misura / Size g Ø20x20x20-Ø63x63x63			

UFFICIO  
TECNICO