

# Codice Dianflex: 334-F306



## ELECTROFUSION END CAP

1201/01-001

### PE100, 4.0mm Fusamatic (Automatic) Pin

PE100 Electrofusion end cap with 4.0mm Fusamatic pin. For gas, water, wastewater, irrigation and mining applications. All fittings are manufactured using virgin PE100 black polyethylene. Electrofusion fittings enable utilities, designers and contractors to create fully welded pipe networks. The production quality, reliability and flexibility of electrofusion fittings provides the certainty and peace of mind needed for polyethylene pipe jointing.

#### Product description:

Electrofusion end cap for gas, water, wastewater, irrigation and mining applications. 4.0mm Fusamatic pin, PE100, Water PN16, Gas 10 Bar. Temperature range on electrofusion fittings -10°C/+40°C.

#### Standards:

Fusion have numerous local and international product approvals as well as ISO 9001 and ISO 29001 quality management system approvals.

Fusamatic branded electrofusion fittings are designed and manufactured to the product standards listed (other product certificates are available upon request).

- EN ISO 15494
- EN 12201-3
- EN 1555-3
- ISO 4437-3
- ISO 4427-3

Note: Regional variations may apply to some of the standards referenced. Please contact us for further details.

#### Features:

- All fittings are manufactured using virgin PE100 black polyethylene
- Water PN16 / Gas 10 Bar (All stated technical specifications depend on PE pipe welded to and any local pipeline pressure regulations)
- Fusamatic pin 4.0mm (automatic method to ensure correct welding parameters are used)
- Rising pin fusion indicators allow for easy monitoring of the fusion process
- Manual welding parameters moulded into the body of the fitting
- All electrofusion fittings are individually numbered for precise tracking
- Permanent batch number - clearly marked for quality control
- Barcode and QR code enables full traceability of each fitting back to raw materials and critical components
- Welding barcode compliant with ISO 13950 and traceability barcode compliant with ISO 12176-4
- Fusamatic branded

#### Accessories:

- Electrofusion control box, pipe cutters, pipe scrapers, pipe alignment and rerounding clamps, generators, Fusion Assist.



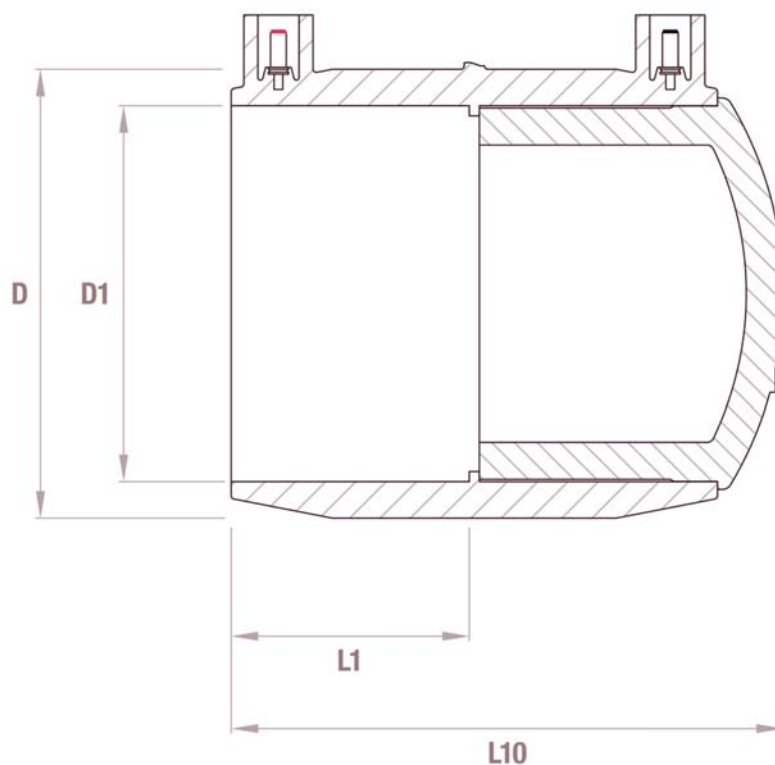

**Reference nos. and dimensions:**

Ref. No.	Fitting Size mm	L10 mm	L1 mm	D mm	D1 mm	SDR Range	Fusion Time Secs	Cooling Time Mins	Theoretical weight / kg
ECBKHFA25	25	82	37.5	33.5	25	11	30	3	0.052
ECBKHFA32	32	84	37.5	43	32	11	45	3	0.08
ECBKHFA40	40	97	44	51.5	40	11	40	5	0.118
ECBKHFA50	50	101	44	61.5	50	11	90	5	0.138
ECBKHFA63	63	115	50	78	63	11	35	3	0.248
ECBKHFA90	90	138	60	109.5	90	11 - 17.6	90	10	0.545
ECBKHFA110	110	164	70	133	110	11 - 17.6	160	10	0.885

**Comments:**

Check that both pipe(s) and fitting to be joined are compatible, only compatible materials should be joined together. Check the PN and SDR rating marked on fitting and compare with that of the pipe. If in doubt, seek advice from the manufacturer. Correct installation procedures should be followed.