



**CARATTERISTICHE:**

Bocchette di mandata ad alette orientabili passo 20 mm.

**COSTRUZIONE:**

Alluminio anodizzato.

**IMPIEGO:**

A parete, in mandata.  
Altezza di installazione:  
2,5-3,5 m.

**FISSAGGIO:**

- Fissaggio standard con clips.
- Fori per viti a richiesta.
- Calamite a richiesta (CL).
- Morsetti a richiesta (KC).

**ACCESSORI:**

- Plenum in acciaio zincato standard o isolato.
- Serranda di taratura in acciaio zincato con alette a movimento contrapposto.
- Controtelaio di montaggio in lamiera di acciaio zincata.

**CHARACTERISTICS:**

Supply grilles with adjustable blades 20 mm pitch.

**CONSTRUCTION:**

Anodized aluminium.

**UTILIZATION:**

For wall installation and for air delivery.  
Installation height: 2,53,5 m.

**FIXING:**

- Standard fixing by clips.
- Holes for screws upon request.
- Magnets on request (CL).
- Clamps upon request (KC).

**ACCESSORIES:**

- Galvanized steel plenum, standard or insulated.
- Calibration damper made of galvanized steel and fins with opposite movement.
- Mounting counterframes made of galvanized steel sheet.

**PREZZI - PRICES**

■ STOCK

BxH		BMAVO	SC	CT CTKC	PBZ1	PBZ11	PBZ2	PBZ12
mm								
<b>200x100</b>		■	■					
<b>300x100</b>		■	■					
<b>400x100</b>		■	■					
		■	■					
		■	■					
<b>200x150</b>		■	■					
<b>300x150</b>		■	■					
<b>400x150</b>		■	■					
<b>500x150</b>		■	■					
		■	■					
		■	■					
<b>300x200</b>		■	■					
<b>400x200</b>		■	■					
<b>500x200</b>		■	■					
<b>• 600x200</b>		■	■					
		■	■					
		■	■					
<b>500x300</b>		■	■					
<b>• 600x300</b>		■	■					

• Rinforzo intermedio - Intermediate reinforcing

**VERNICIATURA - PAINTING:**

Colori RAL 9010: + 15% - Color RAL 9010: + 15%

Altri colori: prezzi a richiesta - Different colors: prices on request

**DESCRIZIONI - DESCRIPTIONS:**

**BMAOV:** Bocchetta a doppio filare di alette (alette frontali parallele al lato corto, posteriori parallele al lato lungo) - Grille with double row of bars (frontal vertical, back horizontal)

**BMAOV:** Bocchetta a doppio filare di alette (alette frontali parallele al lato lungo, posteriori parallele al lato corto) - Grille with double row of bars (frontal horizontal, back vertical)

**ACCESSORI - ACCESSORIES:**

**SC:** Serranda di tarature ad alette con movimento contrapposto - Opposed blade damper

**CT:** Controtelaio di fissaggio in lamiera d'acciaio zincata - Counterframes in galvanised steel sheet profile section

**CTKC:** Controtelaio di fissaggio in acciaio zincato per gancetti KC - Counterframe in galvanised steel for clamps KC

**PBZ:** Plenum di raccordo - Connecting plenum

**DISEGNI - DRAWINGS**

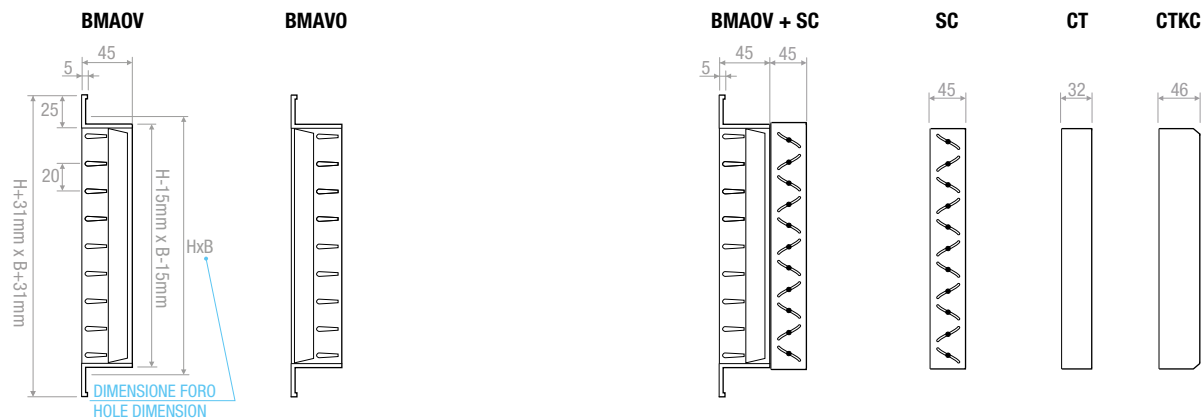

**TIPO DI FISSAGGIO - TYPE OF FIXING**

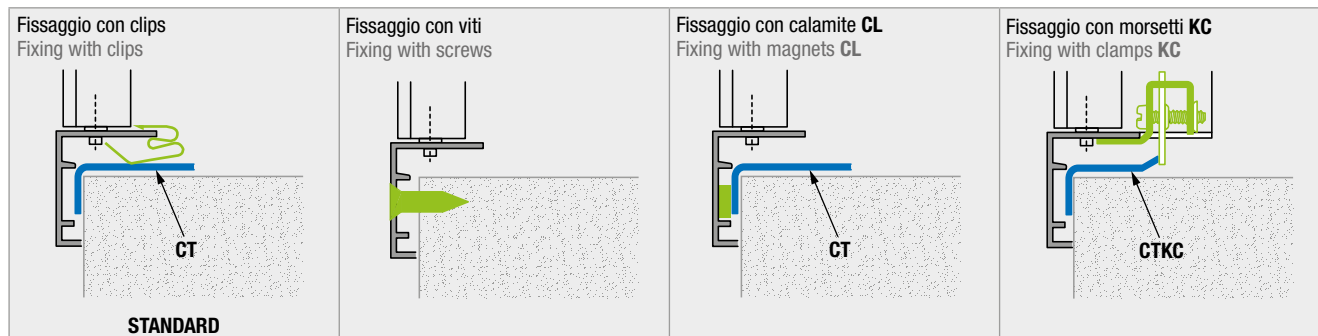

**CL:** - € cadauna - each  
Ogni griglia - Each grille: **4 CL**

**KC:** - € cadauna - each  
da - from 200x100 a - to 1000x300: **2 KC**  
da - from 400x400 a - to 1000x500: **4 KC**

**FORI - HOLE**

**2 Fori - Holes**

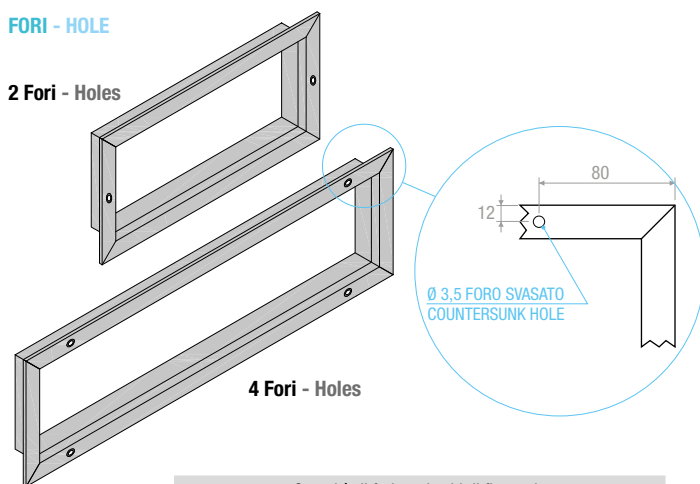

**4 Fori - Holes**

Quantità di fori per le viti di fissaggio Amount of holes for mounting screw					
Lato minore Smaller side	Lato maggiore - Longer side				
	200	250	300	350	≥400
100	2	2	2	4	4
150	2	2	2	4	4
200	2	2	2	4	4
≥250	2	2	2	4	4

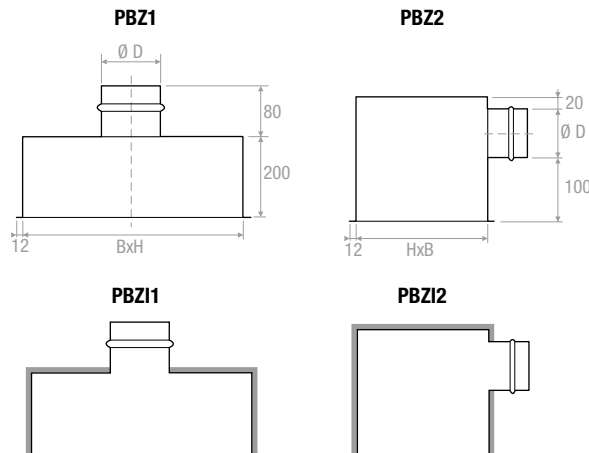

**Plenum isolato esternamente spessore 6 mm**  
Plenum externally insulated thickness 6 mm

DIAGRAMMA SCELTA RAPIDA - QUICK SELECTION DIAGRAM

GRI



TABELLA DI SELEZIONE - SELECTION TABLE

Modello - Model	A <sub>x</sub> [m <sup>2</sup> ]	Q [m <sup>3</sup> /h]		L <sub>WA</sub> [dB(A)]		X <sub>(0,25)</sub> [m]		Dp <sub>t</sub> [Pa]	
		min	max	min	max	min	max	min	max
<b>BMA 200x100</b>	0,0088	110	220	22	41	2,4	4,8	5	20
<b>BMA 300x100-200x150</b>	0,0144	180	350	25	42	3,1	6,0	5	20
<b>BMA 400x100-200x200</b>	0,0200	240	490	25	44	3,5	7,2	5	20
<b>BMA 300x150</b>	0,0228	280	550	26	45	3,8	7,5	5	20
<b>BMA 500x100</b>	0,0256	310	620	27	45	4,0	8,0	5	20
<b>BMA 600x100-400x150-300x200</b>	0,0311	380	760	28	46	4,5	8,9	5	20
<b>BMA 700x100</b>	0,0367	450	890	29	47	4,9	9,6	5	20
<b>BMA 500x150</b>	0,0395	480	960	29	47	5,0	10,0	5	20
<b>BMA 400x200-800x100</b>	0,0423	510	1030	29	48	5,1	10,4	5	20
<b>BMA 600x150-300x300</b>	0,0479	580	1160	30	48	5,5	11,0	5	20
<b>BMA 500x200</b>	0,0534	650	1300	30	49	5,8	11,6	5	20
<b>BMA 700x150</b>	0,0562	680	1360	30	49	5,9	11,9	5	20
<b>BMA 800x150-600x200-400x300</b>	0,0646	780	1570	31	50	6,3	12,8	5	20
<b>BMA 700x200</b>	0,0757	920	1830	32	50	6,9	13,8	5	20
<b>BMA 500x300-1000x150</b>	0,0813	990	1970	32	51	7,2	14,3	5	20
<b>BMA 800x200-400x400</b>	0,0869	1050	2100	33	51	7,4	14,7	5	20
<b>BMA 600x300</b>	0,0980	1190	2370	33	52	7,9	15,7	5	20
<b>BMA 1000x200-500x400</b>	0,1092	1320	2640	34	52	8,3	16,5	5	20

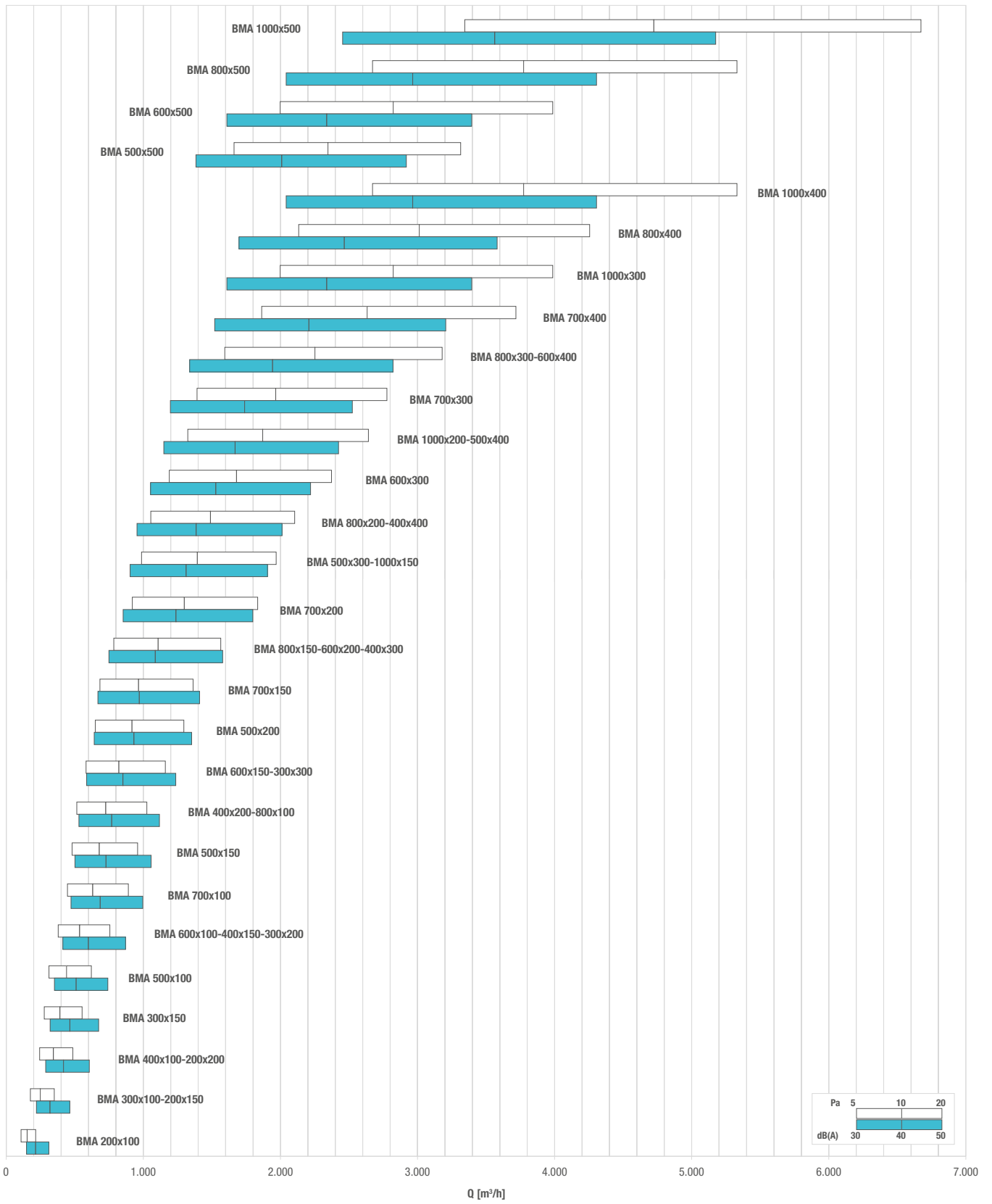