



Codice 415-FKVM...

Categoria 4-15

Prodotto
SFERA AUTOCLAVE SFERIK

DESCRIZIONE DEL PRODOTTO

Vaso di espansione per impianti solari con membrana EPDM. Raccordo 1". Temperatura esercizio da -10 a +140 °C. Pressione max 10 bar. Pressione prova 15 bar. Pre-carica 2 bar.

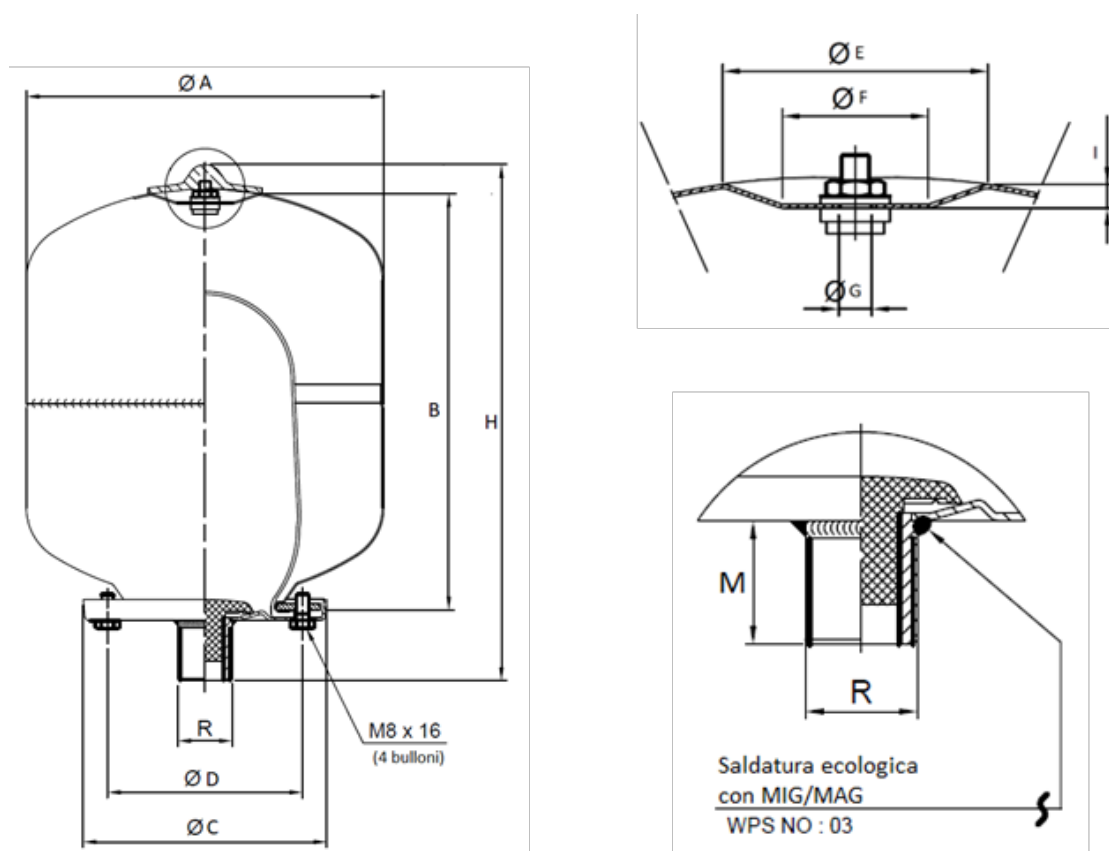

Misure mm	415-FKVM-02	415-FKVM-05	415-FKVM-08	415-FKVM-12	415-FKVM-19	415-FKVM-24	415-FKVM-35
V	2 L	5 L	8 L	12 L	19 L	24 L	35 L
A	120	160	220	280	280	280	380
B	193	251	260	250	360	440	421
C	95	95	140	140	140	140	140
D	75	75	120	120	120	120	120
E	39	52	68	68	68	68	50
F	19	23	25	25	25	25	20
G	8,5	8,5	8,5	8,5	8,5	8,5	8,5
H	242	300	320	300	430	470	479
I	5	7	6	6	6	6	6
M	23	23	31	31	31	31	32
R	1"	1"	1"	1"	1"	1"	1"